

MOTORI ASINCRONI **MONOFASE JMM**

■ 8 MOTORI MONOFASE

• 8.1 COMPONENTI



SERIE JMM

JMM

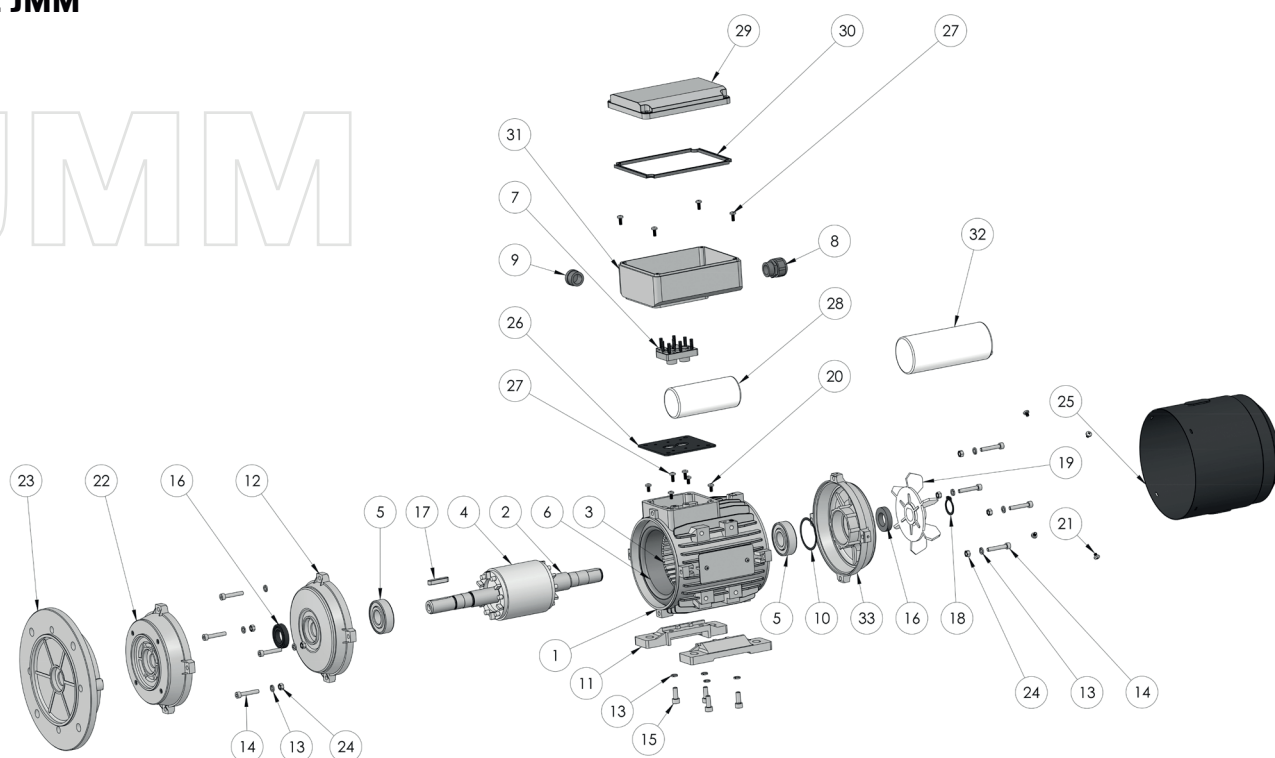

- | | |
|--|---|
| 1) Carcassa | 18) Anello elastico di sicurezza |
| 2) Albero | 19) Ventola |
| 3) Statore | 20) Vite fissaggio scatola morsettiera |
| 4) Rotore | 21) Vite fissaggio copriventola |
| 5) Cuscinetto | 22) Flangia IMB14 |
| 6) Avvolgimento | 23) Flangia IMB5 |
| 7) Morsettiera | 24) Dado |
| 8) Pressacavo | 25) Copriventola |
| 9) Tappo | 26) Guarnizione scatola morsettiera |
| 10) Molla di precarico | 27) Vite coperchio scatola morsettiera |
| 11) Piede per IMB3 | 28) Condensatore di marcia |
| 12) Scudo lato comando per IMB3 | 29) Coperchio scatola morsettiera |
| 13) Rondella | 30) Guarnizione coperchio scatola morsettiera |
| 14) Vite fissaggio per IMB3-IMB5-IMB14 | 31) Scatola morsettiera |
| 15) Vite fissaggio per piede IMB3 | 32) Condensatore ausiliario elettronico |
| 16) Anello di tenuta | 33) Scudo B3 lato opposto comando |
| 17) Linguetta | |

MOTORI ASINCRONI MONOFASE

Grandezza JMM

56 ~ 100

Potenza JMM

0.09 ~ 3 kW

Polarità JMM

2, 4 poli

Settori di utilizzo



• 8.2 DATI ELETTRICI JMM

SERIE JMM 2 POLI

Tab. 8.2.1

2 Poli	Motore JMM	Poli	P_N	n_N	T_N	I_N	$\text{COS}\phi$	η	$\frac{I_s}{I_N}$	$\frac{T_s}{T_N}$	$\frac{T_{max}}{T_N}$	C (450V) μF	C_2^E μF	J Kg m ²	Peso Kg
			kW	min ⁻¹	Nm	A	100%	100%							
230 V - 50 Hz	63 b	2	0,18	2700	0,64	1,40	0,95	56,0	4,0	0,7	1,7	10	10	0,00032	4,0
	63 c	2	0,25	2700	0,88	1,90	0,95	57,0	4,0	0,7	1,7	12	10	0,00041	4,3
	71 b	2	0,37	2710	1,30	2,52	0,98	65,1	3,4	0,8	1,9	20	20	0,00065	6,1
	71 c	2	0,55	2745	1,91	3,72	0,94	68,3	3,8	0,8	2,0	25	20	0,00075	7,2
	80 b	2	0,75	2776	2,58	4,93	0,94	70,7	4,1	0,8	2,1	30	40	0,00110	10,5
	80 c	2	1,1	2733	3,84	6,75	0,96	73,5	4,1	0,9	1,9	40	40	0,00140	11,0
	80 d	2	1,5	2749	5,21	8,87	0,98	74,7	4,2	0,9	2,0	60	60	0,00145	11,1
	90 Sb	2	1,5	2749	5,21	8,87	0,98	74,7	3,6	0,9	1,8	50	60	0,00170	12,6
	90 Lb	2	1,85	2760	6,40	10,9	0,98	74,7	3,9	0,7	1,8	60	60	0,00210	13,1
	90 Lc	2	2,2	2743	7,66	12,9	0,98	75,3	3,9	0,6	1,9	70	85	0,00240	14,4
	100 La	2	2,2	2840	7,40	12,6	0,99	77,0	5,0	0,7	2,0	90	85	0,00250	20,8
100 Lb	2	3	2850	10,1	16,3	0,99	80,4	5,3	0,8	2,1	90	85	0,00270	22,7	

SERIE JMM 4 POLI

Tab. 8.2.2

4 Poli	Motore JMM	Poli	P_N	n_N	T_N	I_N	$\text{COS}\phi$	η	$\frac{I_s}{I_N}$	$\frac{T_s}{T_N}$	$\frac{T_{max}}{T_N}$	C (450V) μF	C_2^E μF	J Kg m ²	Peso Kg
			kW	min ⁻¹	Nm	A	100%	100%							
230 V - 50 Hz	56 c	4	0,09	1377	0,62	0,88	0,95	46,9	2,3	0,8	1,7	6	10	0,00020	3,4
	63 b	4	0,12	1380	0,83	1,10	0,95	52,0	2,0	0,8	1,7	6	10	0,00036	3,9
	63 c	4	0,18	1387	1,24	1,66	0,92	51,6	2,5	0,8	1,8	12	10	0,00044	4,2
	71 b	4	0,25	1316	1,81	2,07	0,97	54,0	2,4	0,8	1,8	16	16	0,00081	6,1
	71 c	4	0,37	1348	2,62	2,63	0,98	62,6	2,8	0,8	1,7	20	16	0,00103	7,2
	80 b	4	0,55	1369	3,84	4,22	0,92	61,6	2,9	0,7	1,7	25	20	0,00180	11,0
	80 c	4	0,75	1342	5,34	4,89	0,97	68,7	3,0	0,7	1,7	35	30	0,00210	11,3
	90 Sb	4	1,1	1349	7,79	7,02	0,95	71,6	3,2	0,6	1,7	40	40	0,00270	12,6
	90 Lb	4	1,5	1372	10,4	9,22	0,95	74,8	3,7	0,7	1,7	50	60	0,00470	14,4
	90 Lc	4	1,8	1350	12,7	11,0	0,96	74,0	3,8	0,7	1,8	60	60	0,00500	19,8
	100 Lb	4	2,2	1408	14,9	12,3	0,99	78,5	4,2	0,5	1,9	70	85	0,00670	19,8
	100 Lc	4	3	1399	20,5	16,6	0,99	79,4	4,2	0,5	1,8	90	85	0,00810	22,5

• 8.3 COLLEGAMENTI ELETTRICI

COLLEGAMENTO MOTORE MONOFASE



• 8.4 DATI DIMENSIONALI JMM

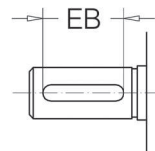
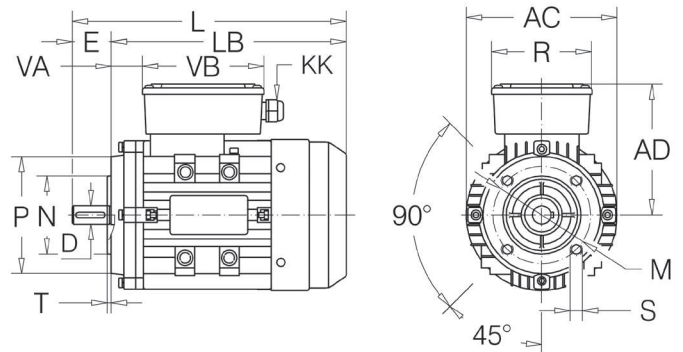
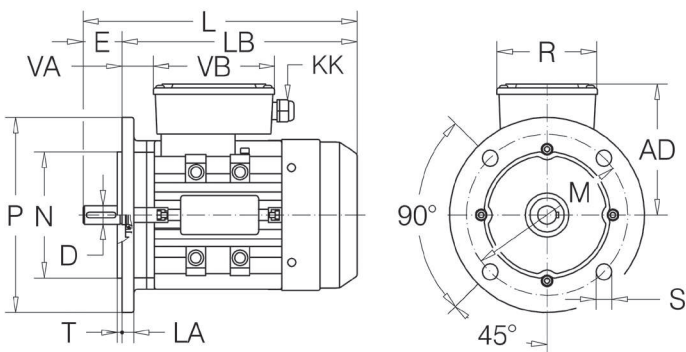
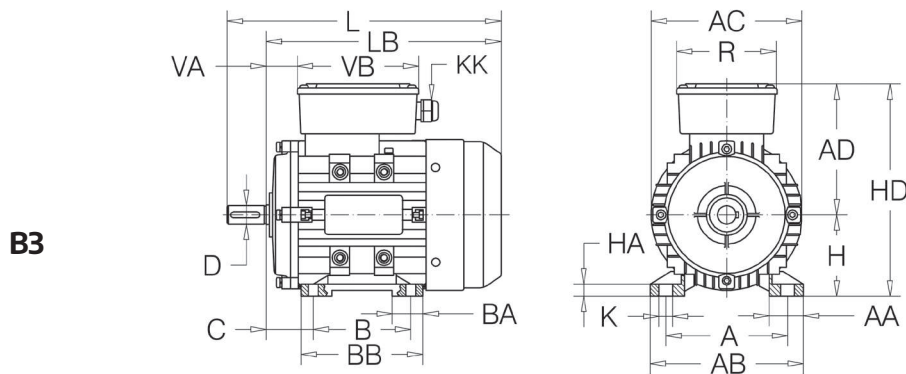

SERIE JMM
Tab. 8.4.1

Motore JMM			Ingombri Principali						Piedi								Flangia							
			AC	AD	H	HD	LB	L	A	B	C	AB	BB	AA	BA	HA	K	IM	M	NJ6	P	LA	T	S
56	2-4		113	112	56	168	176	196	90	71	36	110	89	20	20	6	6	B5	100	80	120	8	3	N°4 7
																		B14	65	50	80	--	2,5	N°4 M5
63	2-4		122	116	63	179	196	219	100	80	40	121	103	28	26	9	7	B5	115	95	140	9	3	N°4 9
																		B14	75	60	90	--	2,5	N°4 M5
71	2-4		139	123	71	194	231	261	112	90	45	133	106	28	23	10	7	B5	130	110	160	9	3,5	N°4 10
																		B14	85	70	105	--	2,5	N°4 M6
80	2-4		156	144	80	224	254	294	125	100	50	161	130	35	35	11	9	B5	165	130	200	10	3,5	N°4 12
																		B14	100	80	120	--	3	N°4 M6
90	S	2-4	174	150	90	240	236	286	140	100	56	174	130	35	33	12	10	B5	165	130	200	12	3,5	N°4 12
	L						286	336		125		155	B14					115	95	140	--	3	N°4 M8	
100	2-4		198	165	100	265	332	392	160	140	63	197	175	50	42	15	12	B5	215	180	250	13	4	N°4 15
																		B14	130	110	160	--	3,5	N°4 M8

SERIE JMM
Tab. 8.4.2

Motore JMM		Estremità d'albero						Tenuta dell'albero						Scatola Morsettiera						
		D	DB	E	GA	Linguetta			Lato Flangia			Lato comando B3 e lato opp.			Mors. N°-Ø	Pressacavo				
F	GD					EB	Øi	Øe	H	Øi	Øe	H	N°-KK	N°-XX		VA	VB	R		
56	4	9	M3	20	10,2	3	3	12	12	22	5	12	22	5	6-M4	PG 11	--	22	118	94
63	2-4	11	M4	23	12,5	4	4	16	12	24	7	12	24	7	6-M4	PG 11	--	23	118	94
71	2-4	14	M5	30	16	5	5	22	15	25	7	15	25	7	6-M4	PG 11	--	31	118	94
80	2-4	19	M6	40	21,5	6	6	32	20	35	7	20	35	7	6-M4	PG 11	--	32	141	112
90	2-4	24	M8	50	27	8	7	40	25	37	7	25	37	7	6-M4	PG 11	--	38	141	112
100	2-4	28	M10	60	31	8	7	50	30	42	7	30	42	7	6-M4	PG 11	--	30	141	112